



gemini
ITALY

**DIGITAL
ARIA FRYER**

電子控制無油煎炸鍋

MODEL NO.: GAF1300

1200-1400W



A GILMAN GROUP BRAND

Please read and retain for future reference.

SAFETY INSTRUCTION - GENERAL

- Use this appliance solely in accordance with these instructions.
- This appliance is for household use only, not for commercial purpose.
- Remove all packaging material from the appliance before use.
- This appliance shall not be used by children of 0 to 8-year old.
- This appliance can be used by children older than 8-year old and persons with reduced physical, sensory or mental capabilities or lack of experience and knowledge, but only if they have been given supervision or instruction concerning use of the appliance in safe way and understand the hazards involved.
- Children should be supervised to ensure that they do not play with the appliance.
- Cleaning and maintenance must not be done by children.
- Have any repairs carried out solely by a qualified electrician. Never try to repair the appliance yourself.
- Do not handle the plug or appliance with wet hands.
- Do not immerse the main body in water.
- Children shall not play with the appliance.
- Do not leave the appliance unattended when connected to the mains supply.
- Keep hair, loose clothing, fingers and all parts of the body away from openings of the appliance.
- Only use the attachments/accessories supplied with the product.

SAFETY INSTRUCTION - ELECTRICITY AND HEAT

- Ensure the appliance is in placed on a horizontal, even and stable surface.
- Verify that the mains voltage is the same as that indicated on the rating plate on the appliance before use.
- Make sure that you always use a grounded wall socket to connect the appliance.
- Always remove the plug from the wall socket when the appliance is not in use.
- Remove the plug from the wall socket by pulling the plug, not the power cord.
- Make sure that the appliance, the power cord and plug do not make contact with water.
- Make sure that the appliance, the power cord and plug do not make contact with hot surface, such as a hot hob or naked flame.
- Check the appliance's power cord regularly to make sure it is not damaged. Do not use the appliance if the power cord is damaged. If the power cord is damaged, it must be replaced by an electrical technician or a person with similar qualification, in order to avoid any hazards.
- Never use the appliance in the vicinity of flammable material.
- Certain part of the appliance may get hot, such as air outlet. Do not touch these part to prevent scalding yourself.

SAFETY INSTRUCTION - DURING OPERATION

- Do not place the appliance against a wall or against other appliance, it should be placed with a minimum distance of 10cm away.
- During operation, hot steam is released through the air outlet. Keep your hands and face at a safe distance away from the steam and the air outlet. Also be careful of hot steam and air when you remove the frying basket from the appliance.
- Pay attention to any accessible surfaces that may become hot during use.
- Slight smoke on the first use is a normal occurrence. It will disappear shortly afterwards.

PRODUCT OVERVIEW

Aira Fryer

1. Touch screen with LCD display panel
2. Upper housing
3. Main cord
4. Body case
5. Window door
6. Air outlet
7. Air inlet
8. Bake tray/ Oil collection tray
9. Multi-functional grill rack
10. Frying basket with detachable handle
11. Food separator
12. Kebab sticks (4 pieces)
13. Bread toast rack

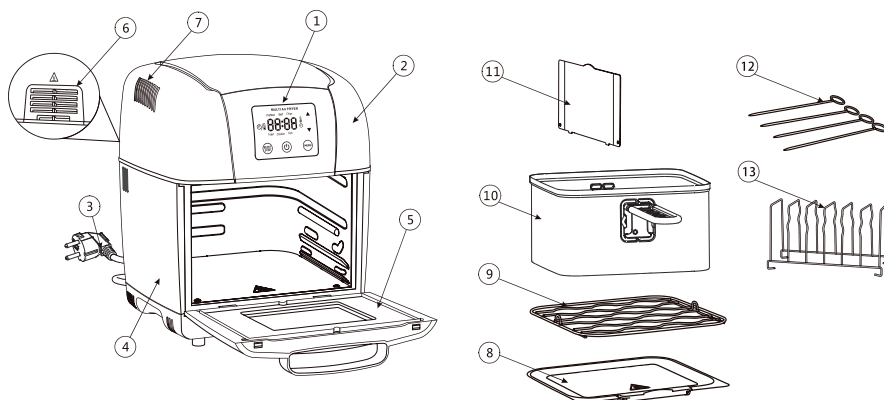

Touch screen control panel

1. Touch control panel with LCD display
2. Temperature (65°C-200°C) / Timer setting (1-30mins)
3. Increase button
4. Decrease button
5. Start/Stop button
6. Power ON/OFF / Cancel button
7. Cooking programs :
(DIY, Meat, Fries, Toast, Chicken, Fish)

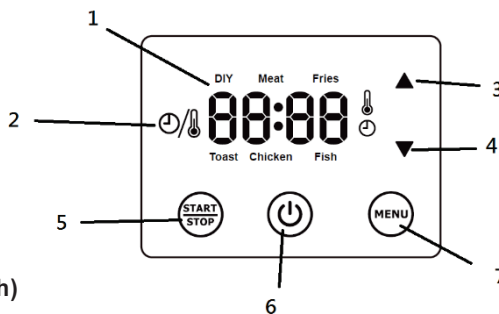

ASSEMBLY INSTRUCTION

- Place the appliance on a stable, horizontal and level surface. Leave at least 10cm free space on the back and sides, and pay attention away from curtains, wall covering and other combustible materials.

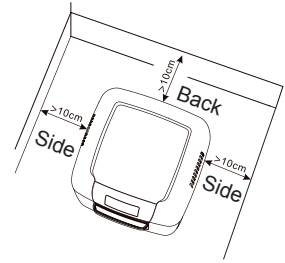

Bake tray/ Oil collection tray :

- Firstly, open the front door, slide the bake tray into the fryer on the inner base. (See Pic.1 - 4)

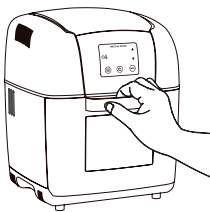

Pic.1



Pic.2



Pic.3

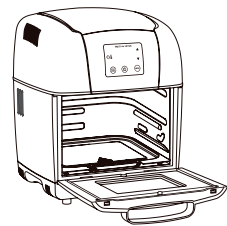

Pic.4



- Insert the Multi-functional grill rack in along the guiding groove that built on the sides of inner wall. (See Pic.5 - 6)

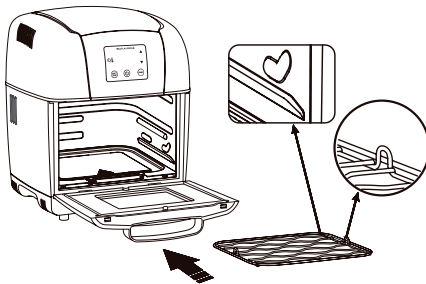

Pic.5

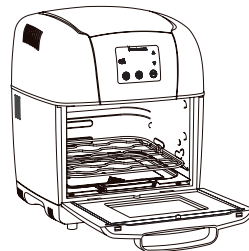

Pic.6

NOTE:

- Please always keep the bake tray stay in the lowest layer for gathering oil from fried ingredients.
- Choose proper accessories for different cooking.
- Please use the GLOVE to take out the multi-functional grill rack or bake tray after cooking finished.

Basket with detachable handle:

The handle should always be used when taking the basket in and out of the unit. The metal locking hook needs to be in place before lifting the basket. (See Pic. 7 - 8)



Pic.7



Pic.8

To place the handle on the basket, squeeze the handle together in the open position (See Pic.9). Then attach it to the basket with the hooks facing down and bottom-up installation (See Pic.10), lock in place with metal hook securely before hold up the basket. (See Pic.11)



Pic.9



Pic.10

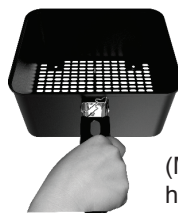

(Metal locking hook must be locked in place)

Pic.11

Basket :

After fill ingredients into the well-assembled Basket with its handle, put the basket into the inner chamber, then dismantle the handle from basket and close the front door. (See Pic.12 - 15)



Pic.12



Pic.13

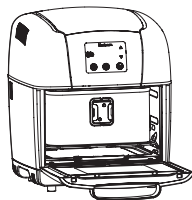

Pic.14

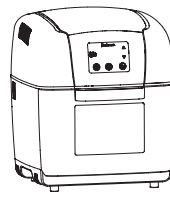

Pic.15

Food separator :

Insert a food separator in the middle of the frying basket to separate the different ingredients. (See Pic.16)



Pic.16

NOTE:

- Please always keep the bake tray stay in the lowest layer for gathering oil from fried ingredients.
- Do not let food exceed the basket. If the ingredients may be expansion after heating, count the amount according to the heated volume.
- There is a safety switch for operating safety. (See Pic.17)
- When the front door closed properly, and machine can only start operation.

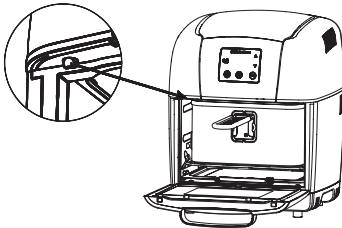

Pic.17

Bread toast rack :

Place the slide breads into the toast rack on the bake tray (Max 6 slices); Then put the bake tray together with breads and toast rack into the inner chamber; And then close the front door before toasting.

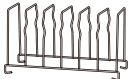

Kebab sticks :

Place meat or vegetable on the skewers then place them on top of the multi-functional grill rack inside the unit, slide the bake tray into the fryer on its inner base.



OPERATING INSTRUCTION

Mode Choosing

- Connet the the unit to the wall socket, the Power ⏻ button will light twinkly with a long “beep” sound at same time.
- Press the Power ⏻ button slightly, the digital panel will light all, and the screen show the default time and temperature alternately, “30:00 ⌚” 200°C 🌡️”
- At this time, there are two kinds of operating modes for users to choose. The first is Menu mode, the second is Manual mode.
- Menu mode: The appliance has been set in five common foods menu for users to choose.
- Manual mode: Choose DIY menu, allows the users to set according to different foods, set temperature and frying time. Set the temperature from 65°C to 200°C and time up from 1 to 30 minutes manually.

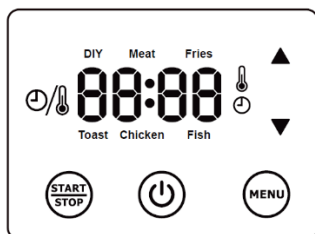





NOTE:

- If you want to stop the program for a while and continue later, you can press the “Start/ Stop” button to pause the process, and can press the “ start/ stop” button again to continue the program.
- If you press the “Start/ Stop” button during cooking and then open the door, the operation will be pause. When you close the door within 3 minutes, the program will continue with your previous setting. The program will stop if door keeps opening more than 3 minutes and need to reset your menu again.
- If you need pre-heat, choose DIY menu, adjust the required time manually.

Cooking setting

- Menu mode: In the menu recipes, there are SIX kinds of function menu, respectively: DIY, Meat, Fries, Fish, Chicken, Toast.
- Press “MENU” button once, the first recipes of “DIY” start flashing, click the “MENU” button once more, the next recipe light flashing, and press the “MENU” button one by one. The recipe will flash one by one.
- While a recipe is flashing, press the START/STOP button, the appliance begins to work under the default temperature and time. The preset cooking time and temperature are listed in the table below.

| | DIY | Meat | Fries | Toast | Chicken | Fish |
|--------------------|-----|------|-------|-------|---------|------|
| Times (Minutes) | 3 | 10 | 20 | 6 | 20 | 14 |
| Temperature (° C) | 180 | 160 | 180 | 190 | 180 | 180 |

- Manual mode: When you need to set different temperature and time to cook different foods, recommend to use the manual mode. i.e. DIY menu setting.
- Press the (time/temperature) switch button , the default time/tempsetting flashes, when the time indicator  lights on, press the ▲ or ▼ button to adjust the time. After adjusting time and then press the  button again to set the temp, the temperature display is blinking, the temperature indicator  lights on, press the ▲ or ▼ button to increase or decrease the temperature.
- After time and temperature setting done, press “START/STOP” button to start the cooking process.
- In the process of cooking, regular or irregular flip food, to help to cooking more evenly.
- Press the ▲ or ▼ button for a long time, can quickly adjust the time and temperature.

CAUTION:

- As ingredients differ in origin, size, shape and brand, please adjust the best cooking time and temperature accordingly for your ingredients.
- During cooking, the basket, toast rack, grill rack, sticks and tray’s temperatures are very high. Pay attention to the hot surface and do not touch them with bare hands;
- Every time when you pull out the basket to flip the foods need to use handle, then push the Basket into the Inner chamber again, and press “START/STOP” button to continue working.

Cooking finish

- When the appliance is finished cooking, it will be heard 5 “BEEP” sounds, its heater has stopped heats up, but its fan need to work continuously until the temperature of center of the Inner Chamber drop to 120°C.
- Open the front door, then assemble and lock the handle on the basket, and make sure the handle and basket are fastened tightly together with the metal hook. Hold the handle, take out the basket.

DANGER:

- When take out the basket from the appliances, never try to unlock the Handle and the Basket. It’s dangerous.

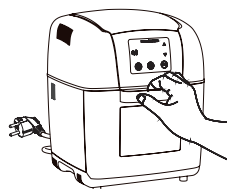

CAUTION:

- The Basket may be high temperature, never try to touch it with bare hand to avoid injuries.

TIP:

- If the ingredients are not well cook yet after cooking, simply put the basket back into the appliance and add few more minutes of extra cooking time again. Certain part of the appliance may get hot, such as air outlet. Do not touch these part to prevent scalding yourself.
- Remove the cooked ingredients on a plate or tableware. (See Pic.18)
- After cooking finished, unplug the power cord from wall to wait the unit chill down for safety cleaning and storage.
- To prolong the service life of the Aria fryer and its components, please let the fryer cool down when operate continuously for around 30 minutes and start another cook work.

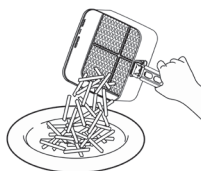
**Pic.18**

CLEANING AND STORAGE

Clean the appliance after every use. Do not clean the frying basket and the interior of the appliance by metal kitchen utensils or abrasive cleaning materials, as this may damage their non-stick coating.

- Remove the plug from the socket and let the appliance cool down completely.
- Wipe the exterior of the appliance with a moist cloth.
- Clean the accessories with hot water, some detergent and a non-abrasive sponge.
- Remove any remaining dirt by degreasing liquid.

NOTE:

- All accessories are dishwasher-proof.
- Unplug the appliance and let it cool down completely before storage
- Make sure all parts are cleaned and dry before storage.

TROUBLESHOOTING

| PROBLEM | CAUSE | SOLUTION |
|---|---|---|
| The Digital Aria Fryer does not work | The appliance is not plugged in | Put the main plug in an earthed wall socket |
| The ingredients fried with the Digital Aria Fryer are not well cooked | The amount of ingredients in the frying basket is too big | Put smaller batches of ingredients into the frying basket. Smaller batches can be fried more evenly |
| | The set temperature is too low | Adjust the temperature to the required temperature setting |
| The ingredients are fried unevenly in the Digital Aria Fryer | Certain types of ingredients need to be shaken halfway through the preparation time | Ingredients that lie on top of or across each other (e.g. fries) need to be shaken halfway through the preparation time |
| Fried snacks are not crispy | The type of snacks meant to be prepared in a traditional deep fryer | Use oven snacks or lightly brush some oil onto the snacks for a crisper result |
| White smoke comes out from the appliance | You are preparing greasy ingredients | When you fry greasy ingredients in the Aria fryer, a large amount of oil will leak into the plate. The oil produces white smoke and the plate may heat up more than usual. This does not affect the appliance or the end result |
| | The bake tray still contains grease residues from previous use | White smoke is caused by grease heating up in the bake tray. Make sure you clean the bake tray properly after every use |
| Fresh fries are fried unevenly in the Digital Aria Fryer | You did not use the right type of potato | Use frozen fries from super market and make sure that they stay firm during frying |
| | You did not rinse the potato sticks properly before you fried them | Rinse the potato sticks properly to remove starch from the surface of the sticks |
| Fresh fries are not crispy | The crispiness of the fries depends on the amount of oil and water in the fries | Make sure you dry the potato sticks properly before you add the oil Cut the potato sticks smaller for a crisper result Add little olive oil for a crisper result |

PRODUCT SPECIFICATIONS

Model no.: GAF1300
Voltage: 220-240V~
Frequency: 50/60Hz
Output power: 1200 - 1400W
Product dimensions: 259(W) x 325(H) x 283(D) mm

閱讀下列說明事項並請妥善保管，以供日後參考。

安全指引 - 一般安全

- 請按照這些說明事項, 使用本產品。
- 本產品僅供家用，不作商業用途。
- 使用前，請將所有包裝材料拆除。
- 0至8歲的兒童不應使用本產品。
- 超過8歲的兒童可使用本產品，但請勿由肢體不健全、感覺或精神上有障礙或缺乏相關經驗和知識的人使用，除非有負責他們安全的人對他們使用本產品進行監督或指導。
- 請務必看顧好兒童，以確保他們不玩耍本產品。
- 兒童不應清潔或維修本產品。
- 當需進行任何維修，必須由專業維修人員進行維修。永遠不要嘗試自己修理本產品。
- 手濕時不可以接觸電源插頭或本機。
- 主機不可以浸入水中。
- 兒童不可以把玩本機。
- 本機開著後不可以無人監管。
- 當本機開著時，頭髮、鬆身衣物、手指和身體其他部份都要離開本機。
- 只使用隨機附送的配件。

安全指引 - 電子和熱能產品

- 請把本產品放置在平穩的表面上使用。
- 使用相符的電源和電壓，以防止觸電。
- 本產品只能使用帶接地線的電源插座。
- 當本產品不使用時，請從牆上的插座中拔掉插頭。
- 從牆上插座中拔掉插頭時，應拿著插頭而不是電源線。
- 確保本產品、電源線和插頭不與水接觸。
- 確保本產品、電源線和插頭不接觸發熱表面，如明火。
- 定期檢查本產品的電源線以確保其沒有損壞。如果電源線損壞，請勿使用其產品，並須由專業維修人員來更換，以避免出現任何危險。
- 切勿在易燃材料附近使用本產品。
- 本產品的某部分可能會發熱。不要觸摸這些部分，以防止燙傷自己。

安全指引 - 操作期間

- 不要把產品貼近牆身或其他電器，保持距離至少10厘米以上。
- 使用產品時，熱空氣和熱蒸氣通過出風口釋放。勿把手和臉貼近本產品。當你拿出籃子時要小心被熱蒸氣和熱空氣弄傷。
- 使用時，請注意碰到熱表面。
- 在第一次使用本產品時，會有輕微的煙霧，均屬正常的。不久後，將會消失。

部件示意圖

無油煎炸鍋

1. 輕觸式顯示屏
2. 上殼
3. 電源線
4. 機身
5. 主機門
6. 出風口
7. 進風口
8. 烤盤/盛油盤
9. 多功能烤架
10. 炸籃連可拆式手柄
11. 食物分隔器
12. 串燒棒 (共4支)
13. 麵包多士架

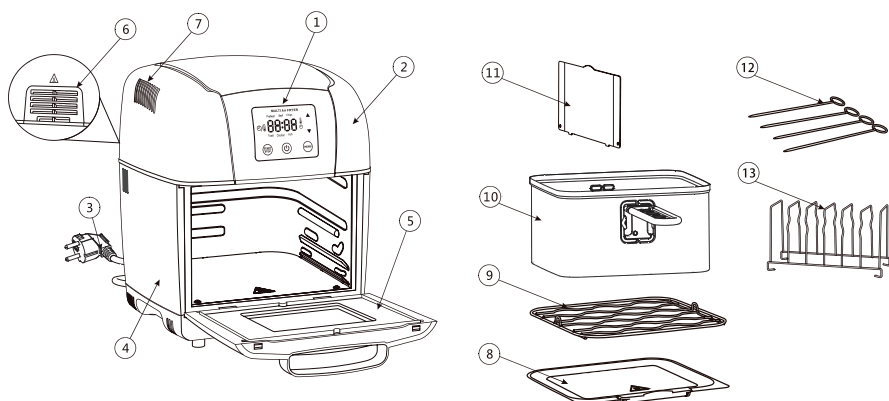

控制面板

1. 輕觸式控制面板及LCD顯示屏
2. 時間/溫度設定鍵
(時間設定範圍: 1-30分鐘; 溫度設定範圍: 65°C- 200°C)
3. 增加鍵
4. 減少鍵
5. 開始/暫停
6. 電源開關/取消鍵
7. 烹調程式:
DIY自選程式、肉類、薯條、多士、雞肉、魚類

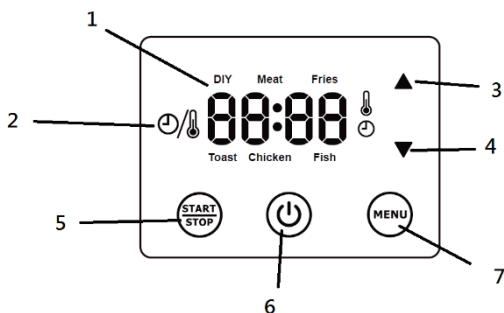

安裝說明

- 將產品放置在平坦的表面上。在背面和側面預留至少10厘米空間，並注意遠離窗簾，牆布和其他可燃材料。

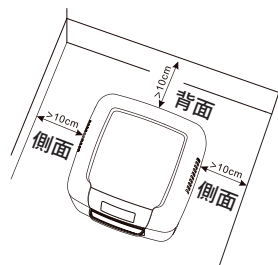

烤盤/ 盛油盤

- 打開機門後，將烤盤/盛油盤推進入機裡，請沿著內壁兩側的引導凸位推進。(參閱圖1 - 4)



圖1

圖2

圖3

圖4

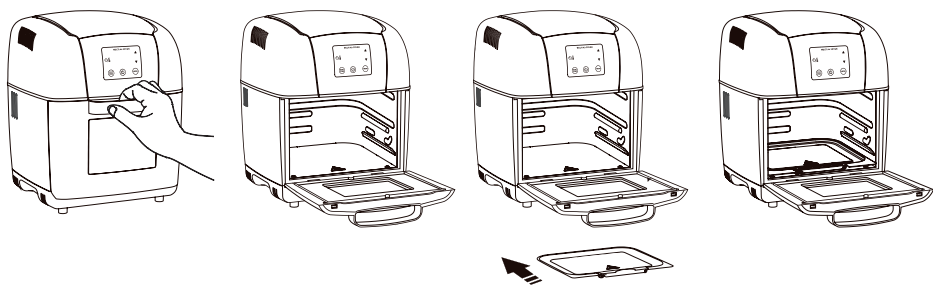
多功能烤架

- 放入多功能烤架。請沿著內壁兩側的引導凹位推進。(參閱圖5 - 6)



圖5

圖6

注意：

- 請將烤盤/盛油盤放在最低層，以便從油炸食材中收集油份。
- 為不同的烹飪選擇合適的配件。
- 烹飪完成後，請使用隔熱手套取出炸籃或烤盤/盛油盤。

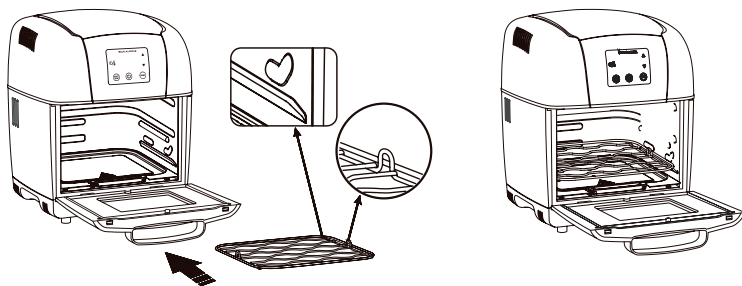
炸籃子配可拆式手柄

- 放入或取出炸籃時，應使用手柄。在提起籃子之前，必須將鎖鈎固定到位。
(參閱圖7 - 8)



圖7



圖8

- 將手柄安裝在炸籃上。首先把鈎子向下(圖9)，從下移上裝上於炸籃扣位內(圖10)，再將鎖鈎固定扣緊使不能鬆掉，才可提起炸籃。(圖11)



圖9



圖10



(手柄的鎖鈎
必需安裝扣緊)

圖11

炸籃

- 將食材放進炸籃及裝上手柄後，放入機內，然後移除手柄並把機門關上。
(參閱圖12 - 15)



圖12



圖13



圖14

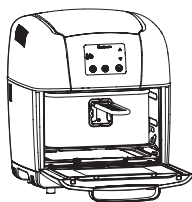

圖15

食物分隔器

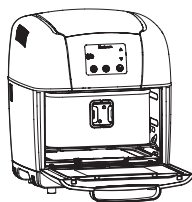
- 在炸籃中間插入食物分隔器, 可供隔開不同食材。

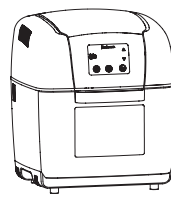

圖16

注意：

- 請將烤盤/盛油盤放在最低層, 以便從油炸食材中收集油份。
- 不要讓食材超過籃子。如果加熱後食材會膨脹, 請預計加熱後的體積。
- 有一個安全開關在機門左上方, 以確保操作安全。(參閱圖17)
- 當機門關上時, 產品才能操作。



圖17

麵包多士架

- 將烤麵包多士架放在烤盤/盛油盤上 (最多可放6塊); 然後將烤麵包架連同烤盤/盛油盤放入機內; 然後關上機門。



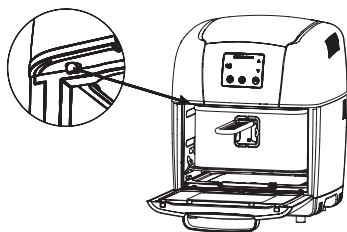



串燒棒

- 將肉類或蔬菜串在串燒棒上，並將它們放烤架上，然後將烤架連同盛油盤盤放入機內；然後關上機門。

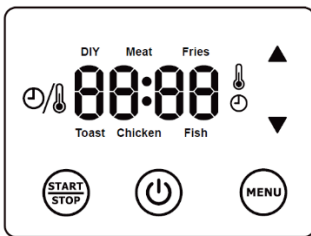

使用說明-模式選擇

- 把本機連接電源，電源鍵  會同時閃爍一聲“be”聲。
- 輕按電源鍵 ，控制面板全部點亮，屏幕交替顯示默認時間和溫度，“30:00 ”及“200°C 











注意：

- 如果您想暫停程序一段短時間並稍後繼續，可以按“開始/停止”鍵暫停該過程，然後再次按“開始/按下”鍵繼續該程序。
- 如果在烹調途中按下“開始/停止”鍵之後開門，當三分鐘內關門，之前的烹調程序會繼續，過了三分鐘後關門，烹調程序會取消，變回最初的設定，需自行重新設定。
- 如果需要預熱時間，請選擇DIY手動模式，調節時間。

烹飪設置

- 菜單模式：有六種功能菜單，分別為：DIY，肉類，薯條，魚類，雞肉，多士。
- 按“MENU”鍵一次，第一種菜單“DIY”開始閃爍，再次按“MENU”鍵，下個種菜單燈閃爍，然後逐個按下“MENU”按鈕。菜單將逐一閃爍。
- 當菜單閃爍時，按START / STOP鍵，便開始於以下默認的烹調時間及溫度工作。以下是6款MENU的默認預設內容只供參照或自行按實際食材調節。

| | DIY | 肉類 | 薯條 | 多士 | 雞肉 | 魚類 |
|--------|-----|-----|-----|-----|-----|-----|
| 時間(分鐘) | 3 | 10 | 20 | 6 | 20 | 14 |
| 溫度(°C) | 180 | 160 | 180 | 190 | 180 | 180 |

- 手動模式：當您需要設置不同的溫度和時間來烹飪不同的食物時，建議使用手動模式，即DIY自行設定菜單。
- 按“時間/溫度”設定鍵 ，顯示屏顯示時間閃爍，時間指示燈  亮起，按  或按  鍵調節時間。調整完時間後再按“時間/溫度”設定鍵  一次，溫度閃爍，溫度指示燈  亮起，按增加  或  減少鍵調節所需溫度。
- 完成時間和溫度設置後，按“START / STOP”鍵，便可以開始工作。
- 在烹飪食物的過程中，不時翻轉食物，以確保食物平均煮熟。
- 長按  或  鍵，可以快速調整時間和溫度。

注意：

- 這些設定只供參考，當食材的產地、大小、形狀和品牌不同時，設定亦需作出調校。
- 在烹飪過程中，炸籃，烤麵包架，烤盤/盛油盤和串燒棒的溫度非常高，切勿用手觸摸。
- 每次需先裝上手柄才拉出籃子翻轉食物，再將籃子推入機內，然後按“START / STOP”鍵繼續工作。

烹飪完成

- 當設定的烹調工作完成後，將發出5次“BEEP”聲，表示會停止加熱功能，但風扇會繼續工作，直到機內溫度降至120°C。
- 打開機門，然後將手柄裝到炸籃上，確保把手柄鎖鉤和炸籃扣緊。握著手柄，取出籃子。

危險：

- 從機上取出炸籃時，切勿嘗試解開手柄。這是非常危險。

注意：

- 炸籃外殼很燙，切勿用手觸摸，以免受損。

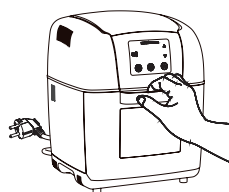

提示：

完成烹調後，若食物效果未如理想，只需將籃子放回本產品中，再多加所需分鐘烹飪時間。本產品周圍及部分機件/配件可能會發熱，如出風口。請勿觸摸這些部件以防止燙傷自己。

- 取出煮熟的食物並放到托盤或餐具上。(參閱圖18)
- 完成烹飪後，從牆壁上拔下電源線，等待本產品冷卻清洗配件及待乾後，才存放。
- 為了延長無油煎炸鍋及其組件的使用壽命，請在連續操作約30分鐘後讓本機完全冷卻，才開始另一次烹調工作。



圖18

清潔及儲存

每一次製作後，需清洗產品，不要用金屬或鋼絲清潔用料清洗產品的籃子和內部，因為這可能會損害他們的不粘塗料。

- 從牆上插座移除插頭，讓產品降溫。
- 用濕布抹擦產品表面。
- 用熱水清洗籃子和盛油盤，使用一些洗滌劑和海綿。
- 你可以用除油液清除遺留下來的污垢。

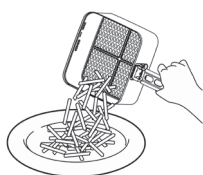
注意：

- 所有可拆式配件都可以用洗碗機清洗。
- 在儲藏前，切斷產品的電源，並使其完全冷卻。
- 在儲藏前，確保各部件是乾淨並已乾透。

疑難排解

| 問題 | 原因 | 解決方法 |
|---------------|------------------|--|
| 產品未能運作正常 | 產品沒有連接插頭 | 把電源插頭連接地插座上 |
| 煎炸鍋內的食材沒有完全煮熟 | 籃子內的食材放入太大 | 將小塊的食材放入籃子內，小塊食材容易受熱 |
| | 設置的溫度太低 | 把溫度設定調到所要求的溫度 |
| 煎炸鍋內的食材沒有平均煮熟 | 某些食材在製作過程中需要不斷翻轉 | 位於頂部或彼此交叉的成分，在製作過程中需要不斷翻轉 |
| 炸的小吃出爐後不脆 | 此食材需以傳統的煎鍋或焗爐烹煮 | 使用焗爐或者在小吃上塗一層油 |
| 鍋內冒出白煙 | 在製作油膩的食材 | 在製作油膩的食材在製作油膩的食物時，大量的油會滲入鍋，油會製造白煙，鍋的溫度加熱時會上升，但這不影響製作結果 |
| | 鍋內殘留餘物或油脂 | 白煙是由於鍋內有油脂引起的，確保每次使用後清洗乾淨 |
| 煎炸薯條不完全熟透 | 沒有使用正確的食材 | 用急凍薯條 |
| | 生薯條之前沒有正確的沖洗 | 沖洗薯條並清除薯條面的澱粉 |
| 煎炸薯條不脆 | 脆度取決於油量和水 | 確保在加油之前薯條是乾的，薯條切幼小一點，加入少量的油 |

產品規格

型號：GAF1300

電源：220-240V~

頻率：50/60Hz

熱量輸出：1200 - 1400瓦

產品尺寸：268(闊) x 325(高) x 283(深) 毫米

請記錄下列產品資料

● 型號

● 機身編號

● 經銷商名稱

● 購買日期

本產品不斷改進中，如功能有所更改，恕不另行通知，如有疑問，請與客戶服務中心聯絡，不便之處，敬請原諒。

說明書內容以英文版本為準

ToolBox Customer Service Centre 客戶服務中心：
4/F, DCH Building, 20 Kai Cheung Road, Kowloon Bay, Hong Kong
香港九龍灣啓祥道20號大昌行集團大廈4樓

Customer Service Hotline 客戶服務熱線：(852) 8210 8210
Service E-mail 電郵地址：8210service@gilman-group.com
Please register now at 請即上網登記：www.toolbox.hk
Website 網址：www.gilman-group.com



Proudly Serviced by:



太平家庭電器